

SEASONS

JUSTINE THEIZEN



hip hop homos

sexualité



STATEMENT S

ORIGIN

The piece **Seasons** was born during the **1000 pièces puzzle** course in April 2019, coached by Cindy Claes. This training is made for young artists looking for professionalism. The artists learn how to manage a stage, how to choreograph, produce and use the right tools to sell their piece. We also had the opportunity to travel to Portugal for an artistic exchange. Throughout the training, we attended **workshops** with artists such as **Benji Reid** and **Ricardo Ambrozio**. Once trained, we had to create our own piece as choreographers and then we had to present a project in front of a panel of Zinnema judges. On the closing night, each participant presented their 6-minutes work in progress. **Seasons** was later presented as a duet and won the **grant** provided by **Zinnema** thanks to the directly related project presented the day before. After several performances of the work in progress in 2019, the piece is evolving with a **new dancer** and a **new focus**. The piece was last performed at the **Lezarts Urbains festival** at the **KVS**.



INTENTION NOTE

THE PIECE

DURATION : 20 MIN

How to represent a **lesbian couple** in a **hip hop dance performance**?

What representations do we have access to otherwise? The most of them end badly: a brutal break-up, betrayal, adultery, suicide or sexualisation, adultery, suicide or sexualisation. So I know **what I don't want to portray**.

But to question the viewer about a positive homosexual relationship and to do so through the hip hop movement, I still need to **develop my research**.

The project aims to show, to **expose a love relationship between two women**.

To tell an **intimate story** and its evolution. All this, with the language of hip hop dance, from which the two performers come from.

Hip hop is a dance style but also a **community**, a culture that was created and mainly dominated by cisgender heterosexual men. There is therefore still very little visibility for women, and even less for Lgbtqia+ communities.



INTENTION NOTE

THE PIECE

Moreover, having grown up within this hip hop culture, while being queer, I was able to find my place in here. Through its **codes**, **languages** and **types of movements**, this culture has allowed me to express myself and **blossom** in my gender expression. I therefore realised that these communities, queer and hip hop, although different in origins and foundations, are **similar** in their value: the **reclamation** of a **marginalized group**.

Now the questions are: am I the only one who feels this way?

Can one community welcome another? If so, what is its representation? How can we provide positive representation and visibility for the queer community by using the codes of the Hip Hop dance community? Through these reflections, **Seasons** came to me.

The central themes of this work in progress are **love**, **passion**, its **evolution**, the representation of **female** and **queer bodies**.



INTENTION NOTE

THE PIECE

Inspired by **our own past relationships** and love stories, we realised, the other performer of this creation **Iza**, and myself, that we had been in several heteronormative relationships, although they were lesbian relationships. How do we **deconstruct** this pattern? We have each developed heavy baggage, trust issues, emotional and sexual blocks... But then, how can we represent a **positive lesbian relationship** if we ourselves have never experienced it? How, through the movement, can we deconstruct our relationship in a society where representations of lesbian relationships are often heteronormative?

With the support of the **Jacques Franck Cultural Centre, Zinnema** and the **Pianofabriek/City Lab**, we started our research in the summer of 2020 during several residencies. Now we would also like to investigate further by including a mobile scenography, such as a **sofa**, as an integral part of the story and a meeting place for the couple. This sofa should be modular so that it can be deconstructed and viewed from different angles. We already have the prototype sofa; but we would like to take the research further and in particular to work with a **scenographer**.

We would also like to deepen our research regarding **dramaturgy**. As a choreographer, I need support to be **guided**, to find a common thread, to tell a story through my movements. So that our story, which is abstract because it is not literal, can be **readable**. We were lucky enough to present a working stage of **Seasons** during the **Lezarts Urbains Festival** in April 2022 at the **KVS** (Royal Flemish Theatre) in Brussels. This festival highlights urban arts and, among others, hip hop dances. The rather young audience of this festival inspired me to offer **Seasons** to secondary schools (from 4th to 6th secondary school). Having discovered my sexuality myself at the age of 15 years old, discovering the existence of the **lgbtqia+** community and a positive representation through art, would have been beneficial in my personal development. Today we have **L'atelier 210** as line producer and a **premiere** planned for **autumn 2024**.

INTENTION NOTE

OBJECTIVES

This play aims to **question the spectator** about a homosexual relationship. It is about showing and exposing a love relationship between **two women**. To tell a personal story, as well as the evolution of it. My goal as a choreographer is to **represent** the LGBTQIA+ community, which is my own community. All of that in the **Hip Hop** community, which is still very reserved about this subject and even about sexuality in general. The central theme of this piece is **love, passion, evolution and bodies**.



DISTRIBUTION

ARTISTS

Justine Theizen
(chorégraphe et danseuse)

@justinetheizen
@Zackthedrag

I am **Justine Theizen**, a 25-year-old dancer and choreographer. First trained in Hip Hop for several years, then in **Krump** for 3 years, I grew up in an **urban culture**, between battle, choreographic competitions and video clip. In 2019, I participated in the **1000 Pieces Puzzle** training for emerging artists, organised by **Cindy Claes**, in collaboration with **Zinnema**. This experience opened up my artistic world to creation, **storytelling** and hip hop theatre.



I won this training thanks to the debut of my piece "**Seasons**", which enabled me to take part in the 2020 edition of the **Brussels Bijou Competition**, organised by **Zinnema** in collaboration with **Bozar**, which rewards promising dance creations. This last opportunity, which I also won, allowed me to create a first stage of work of 20 minutes for **Seasons**. Then, due to lack of funding (and a covid period), the Seasons project was put on hold. However, my career as a dancer/performer was taking off in parallel. Between 2019 and 2022 I was a dancer/performer in several creations: **Chikara by Ronin**, **Solomon x Sheba by WANP**, **La Ave by Nina Munoz**, **Ruuptuur by Mercedes Dassy**, **Categoreez by Yassin Mrabtifi** and **Free Dance Espace by Lorena Spindler**. In addition, since 2020, I have been accompanied by the management and distribution agency **Get Down - Dancers Management ASBL**. Today, I am also very interested in cinema and have had the opportunity to act and dance in various short films - such as "**Tarot**" directed by Alice Khol - or films - such as "**Rebel**" by Adil and Bilal. I have created my character **Dragking @Zackthedrag** since June 2022 and I have performed for **Sassy Cabaret**, Mama's open Mic, Fame Festival, Crashtest and Playback In addition, at the beginning of 2023, I am organising a Queer Battle at the **Rendez-Vous Get Down** at CC **Jacques Franck**. My art gives me the opportunity to represent my community; every project I decide to get involved in brings me a little closer to this goal. I am a queer hip hop artist.

DISTRIBUTION

ARTISTS

Isabelle Audoan - IZA
(dancer)

@iza.a__

Iza is a 26 year old dancer. She first started with classes in various styles. She has always been attracted to the diversity of dance, but it is towards Hip Hop that she found a real attachment. After the choreographic world, comes the world of freestyle. She seeks to develop her own movements in relation to her history and her sensitivity. She is mainly inspired by **nature**, her **environment**, the people around her and the other artistic fields she practices (painting, drawing, music and singing).

Her dance is mainly characterised by **fluidity**, **structure** and **organics**. She has diversified her experience through competitions, battles, clips, events, workshops, performances and creations. She is also part of the **body percussion company ZIKIT**, the company **We Are Not People** and the **Liège collective CUBE**.



IT'S OK

WORKSHOP

It's ok is a free workshop with an urban movement workshop and a discussion session with a speaker, all based on self-expression and sexuality.

WHO ?

For young people between 16 and 21 years old.

PURPOSE ?

To help young people express the emotions generated by questioning their sexuality, to educate on sexuality, to educate around the notion of 'queerness'.

WHY ?

Sexuality is a taboo topic among young people. Especially when it comes to sexual orientation.

In my experience, for some people, it may generate a lot of emotions. Sometimes it is even difficult to talk about it even with the people you love the most. Dance allowed me to express these feelings and I would like to give young people the opportunity to come together in a place where they can feel safe while being themselves.

PROGRAMME

MOVEMENT

Movement workshop: becoming aware of your body, based on urban movement. **Learn the notion of storytelling**, hip hop theatre.

Duration: 1h30. Discussion: exchange on the workshop but also on the notion of "queer" and "lgbtqia+" and what it represents for them. To make the difference between gender identity and sexual orientation. Discussion about the aim of educating about this community and informing about the different associations if needed.

RETROPLANNING

2024

- fall 2024 (end of October?): opening Seasons - Atelier 210
- October 2024 right before the opening : 3 days setting up at Atelier 210 + 1week residence/repetitions (lights + dancers)
- September 2024 : 2 weeks residence + last residency exit, presentation workin progress to the programmers (1 week lights and scenography + 1 week dancers, lights and scenography)
warning : scenography must be done.
- August 2024 : 1 week (scenography + danseuses + 2 jours dramaturge) + petite sortie de résidence, oeil extérieur
- July 2024 : 1 week (scenography + dancers)
- June 2024 : 2 weeks (2 weeks dancers + 3 days dramatist)
- April 2024 : 1 week (dancers)
- March 2024 : 2 weeks research (Bellone choreograph + scenography)

DISTRIBUTION

ARTISTS

Pierre-Philippe De Vreese - INSK
(Beatmaker and musician)

@insk_music

Insk is a musician (guitar, piano) from a family of musicians. Therefore he has been immersed in music all of his life.

From rock, to jazz, to classical music and finally to electro and hip hop, he draws his influences from everywhere.

As an independent artist, he has produced for artists such as Geeeko and Maes.

Clelia Guendouzi
(singer)

@cleliasart

CLELIA is a 23 year old Belgian artist who is signed to the Brussels label OTT.

Passionate about music from an early age, she started writing poems before writing her first song when she was 15. Through music, she tries to gather and acquire a 'voice' that allows her to get out of a certain powerlessness.

Her purpose is to show that it is possible to make the world dance to melancholy.

TECHNICAL CONDITIONS

TECHNIC

The piece **Seasons** lasts 20 minutes

It requires a display space large enough to accommodate a sofa with the product dimensions shown in the image below:

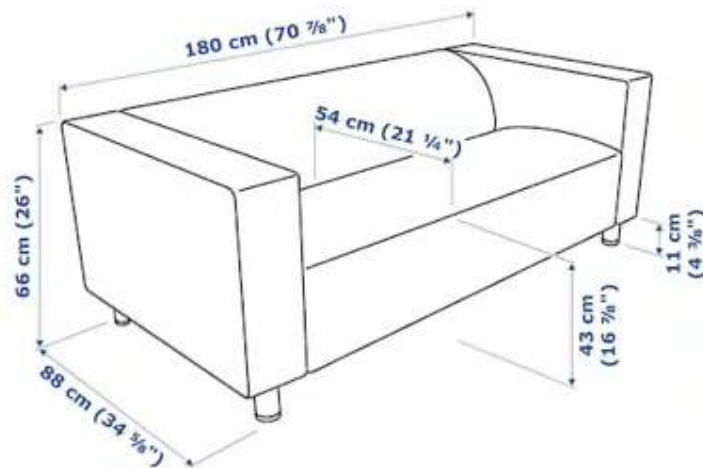

The team is available to invent with you the best playing conditions.

Team on tour : 3 people

For more informations, please contact the following:
Get Down - Dancers Management to get the data sheet of it

PHOTO GALLERY



©Pierre DLK Photography







**Get Down -
Dancers Management**

Contact :
Camille Phillipot ,
Founder and CEO

INSTAGRAM
@getdownagency

FACEBOOK
@getdownagency

WEBSITE
www.get-down.be

PHONE
+32 (0)484 711 699

MAILING
camille.phillipot@get-down.be

